

MARC-15

Modular Advanced Radio Console (MARC)

fifteen channel mainframe with...

MARC-15-8	8 input modules	\$5,775 msrp
MARC-15-12	12 input modules	\$6,299 msrp
MARC-15-15	15 input modules	\$7,325 msrp
Individual modules		\$500 msrp
ARC-16SW	16 in x 3 out switcher	\$995 msrp



an advanced, modular, analog console for On-air Radio, Internet Radio, & Production

- Three stereo Program output mixes (with mono mixdowns) plus Monitor, Headphone, and Cue systems
- 15 channel modular mainframe supports many types of input modules (all with LED illumination)
 - High performance mic modules with 48V phantom power (A/B inputs), (turret control logic & tally for 'A' inputs)
 - Balanced, stereo line level input modules (A/B inputs), (isolated relay source logic for 'A' inputs)
 - Powerful Phone module with hybrid control logic (mainframe supports two phone modules)
 - USB soundcard input module for playing and recording directly in digital from a Windows PC (one per PC)
- Optional Studio Monitor module for Talk studios
- Real VU meters monitor all three Output buses
- Cue-talkback system with built-in amplifier and speaker
- Built-in Timer with manual and automated control
- All I/O is by RJ45 connectors and ten foot wiring is supplied with RJ45 at one end and unterminated at the other end
- Optional 16 x 3 stereo switcher for remote input select... handles large studio jobs

The MARC-15 modular analog console comes in a single 15 channel mainframe size with a wide variety of input and option module configurations. The console supports two phone modules for use with external hybrids. All switches are LED illuminated and ICs are socketed (not surface mount) for reliability. Machine source control is by isolated reed relays. The meter panel hinges up and back for access to I/O connectors and input trim pots. All I/O is by RJ45 connectors and ten foot wiring is supplied with RJ45 at one end and unterminated at the other end (an expensive option in competing products). The MARC-15 is a very low profile, attractive, tabletop design that is flexible, easy to install, reliable, and ideal for any on air or production Radio application.

powerful, flexible, easy to install, and low cost

MARC-15 console

The modular mainframe...

The MARC-15 is available in a single 15 channel mainframe. The mainframe is a fully enclosed metal cabinet with a rear hinging meter panel. The power supply is an external, autosensing 110-220VAC module. The meter panel contains meters for all three buses, a digital timer, and a built in cue/talkback speaker.

The console is compact, low profile,
and a tabletop mount design



Width: 37 1/2"
Depth: 20"
Rear height: 6 3/4"
Front Height: 2 1/8"

The meter panel hinges for
access to console I/O and
trimpots



Many modules to choose from...

The 'Output' module comes standard with the console. The 8, 12, and 15 channel base models can then be configured with any combination of input modules that you choose. There can be a maximum of one 'PC USB' module per PC, two 'Phone modules', and one 'Studio monitor' module per mainframe. Any number of mic or stereo line modules can be added until the 15 open modules in the mainframe are full.



Input modules

Option

Output module

Mic module

Stereo line module

PC USB module

Phone module

Studio monitor module

Output / Monitor / Timer Module

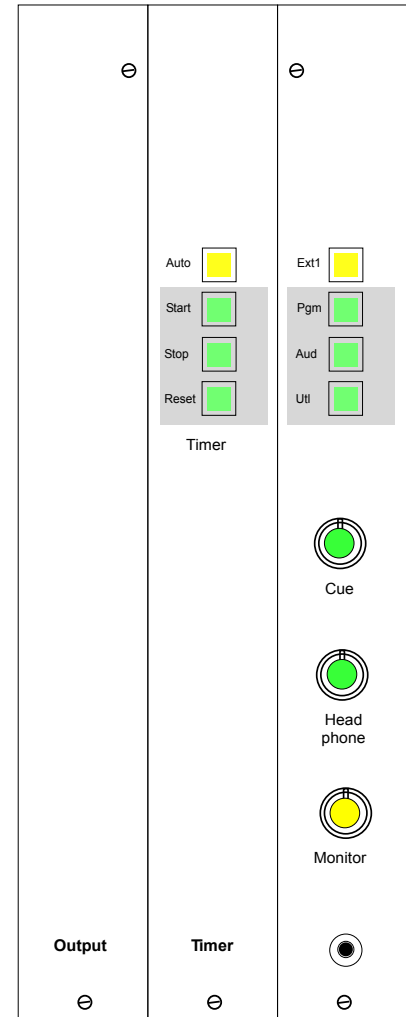
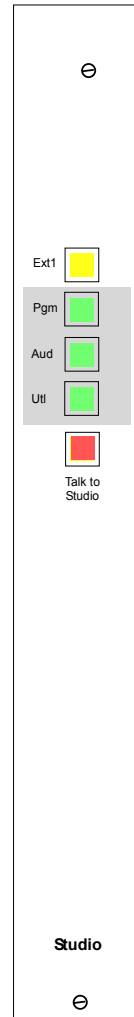
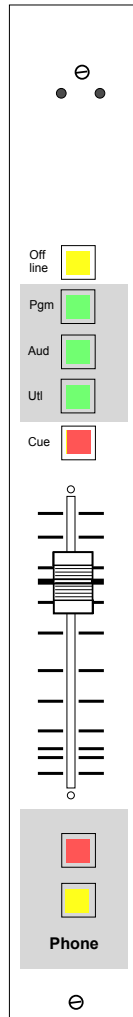
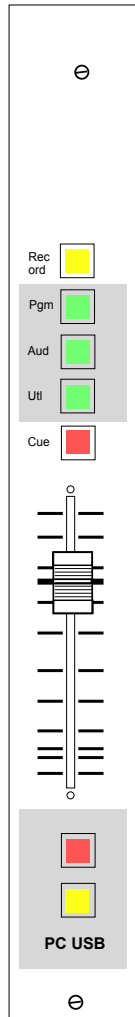
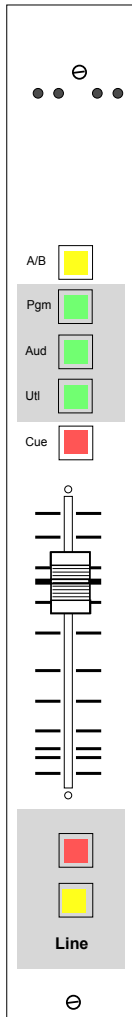
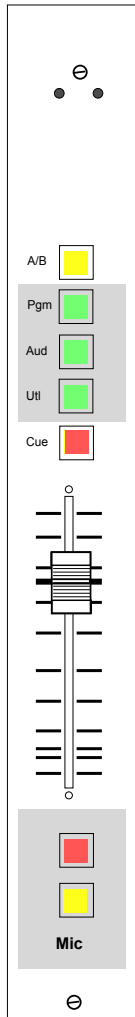

Input modules...

Mic Module

- A/B inputs (two inputs per module)
- Front panel trimpot adjustment
- High performance mic preamps
- 48 VDC phantom power (internally selectable)
- 3 stereo output buses (Pgm, Aud, Utl)
- 'A' input remote channel Turret control (on/off/cough/tally)
- LED illuminated switches

The mic module features an extremely low noise monolithic mic preamp IC for extremely high mic performance. 48 volt phantom power can be internally selected for condenser microphones. The 'A' input supports complete remote studio control of channel on/off/cough/ and talkback.

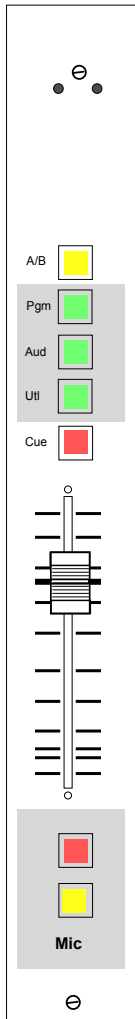

Stereo line module.

- A/B inputs (two inputs per module)
 - Front panel trimpot adjustment
 - Active balanced input amplifiers
- 3 stereo output buses (Pgm, Aud, Utl)
- 'A' input machine source start and stop logic is relay isolated
 - LED illuminated switches

The stereo line input module features extremely low noise and distortion input amplifiers. The 'A' input has reed relay isolated start and stop logic for source control. The relay isolation reduces pops and clicks and ground loops. The 'A' input also supports complete remote studio control of channel on/off/cough/ and talkback for when external mic preamps are used.

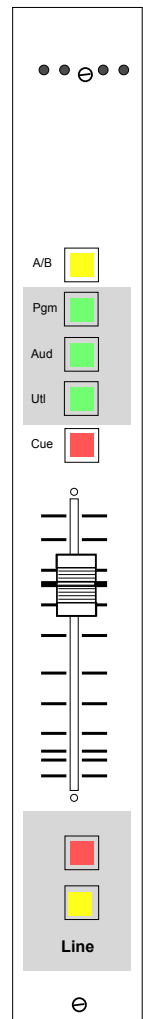

Input modules...

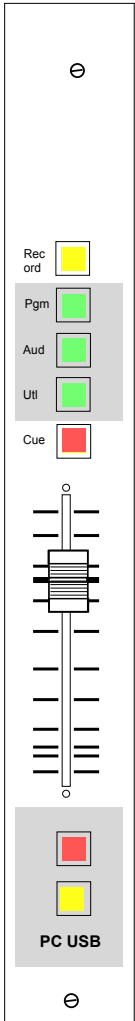

PC USB module

- Play & Record in digital with a Windows PC
- USB sound card functionality built directly into the module
- Connects to the PC by USB
- Use Arrakis software (supplied) or...
any Windows sound compatible software
- Free Arrakis Xtreme Software
 - Triple play and simultaneous record
 - 500 event Cart Play list (with overlap)
 - The Play list is controlled by the channel on-off logic
 - 300 event Jingle wall
 - Phoner recorder-editor
 - much more...
- Full Automation software (optional)
- LED illuminated switches

The PC USB module is ideal for interfacing the console with a Windows PC (XP or VISTA). Because the hardware is Windows compatible, both Arrakis software and 3rd party software (such as Adobe Audition) will recognize and play/record from the module. The Arrakis software is also controlled by the module channel on-off switches to start and stop the playlist just like a cart stack. The Record button start and stops a manual record from the front panel of the module. Powerful Arrakis Xtreme software is supplied free with this module and full automation software is available as well under the Arrakis Xtreme-Solutions program.

Phone module.

The mainframe supports two phone modules
 Each module controls a single external phone hybrid
 Relay isolated logic for control of an external phone hybrid
 Off-line button for caller & console operator only
 Mix minus feed to the caller is a mix of Pgm-Aud-Utl
 Cue button for listening to the caller only
 LED illuminated switches

The MARC-15 supports two phone modules for two external hybrids. Each phone module (caller) has its own mix-minus bus that includes the other phone module (other caller). The convenient 'Offline' button switches the module so that the caller hears the console mic only and the console is fed by the caller. When not in off-line mode, the caller mix-minus is fed from a mix of the three output buses (Pgm, Aud, & Utl). Relay isolated logic control of the external hybrid is actuated by the module on-off buttons.

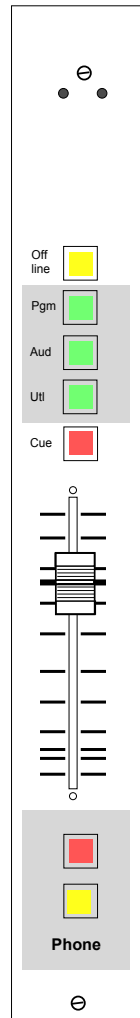

Option module...

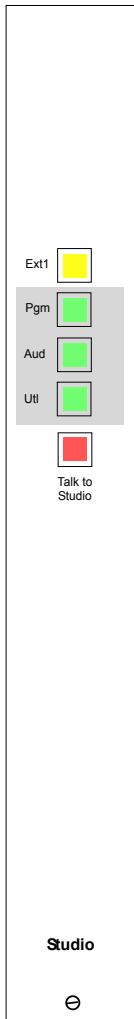

Studio Monitor module (optional)

This module is used to provide monitor and talkback functions between the control room (where the console resides) and a separate studio (usually a talk studio). The studio monitor feed is selected from an external input (usually Air) or the three main console buses (Pgm, Aud, Utl). If the studio is on air, Ext (Air) or Pgm will usually be selected. If the studio is being recorded for later playback, the Aud or Utl buses would usually be selected.

The 'Talk to Studio' button sends the control room mic to the muted monitor and unmuted headphone feeds that are fed to the studio. This enables the console operator to speak to the host and talent in the studio. The host and talent in the studio can 'talk back' to the console operator by activating the 'talkback' logic from their respective mic module which feeds their mic to the console cue speaker and console headphones.

Technical

This module has stereo, active balanced audio outputs for a muted studio monitor feed and an unmuted earphone feed. External audio power amplifiers are required for both the studio monitor speakers and earphones.

A studio muting logic output is provided for a studio on air light. This output is reed relay isolated (50 milliamps max) to remove a potential ground loop. The reed relay should be used to trigger another relay for powering the on air light.

Output module...

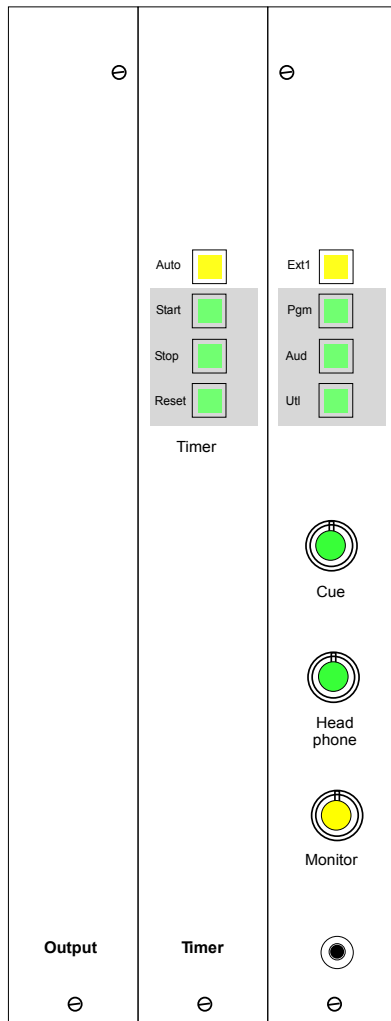

The Output Module

- All active balanced inputs and outputs
- Both stereo and mono outputs from the three output buses
- Relay isolated muting logic to eliminate ground loops
- LED illuminated switches

This module is 3 modules wide and contains the output, monitor, and timer control circuitry on a single PC board. The main stereo buses (Pgm, Aud, Utl) each have stereo AND mono mix outputs for convenience.

Technical

All audio inputs and outputs on this module are stereo, active balanced. The audio output for the control room monitor speakers requires an external audio power amplifier. The headphones have both a stereo, balanced, line level output for an external amp and a headphone amp output for driving low impedance headphones. The headphone jack for the headphone amp is located at the front rear of the control room monitor module section.

A control room muting logic output is provided for an on air light. This output is reed relay isolated (50 milliamps max) to remove a potential ground loop. The reed relay should be used to trigger another relay for powering the on air light.

Remote input and output selection...

- Add 16 stereo inputs to your MARC-15 console
- Balanced stereo with Trimpot adjust for all inputs
- 3 stereo outputs for 3 console channels
- Windows PC controlled for ease of use

The MARC-15 console supports up to 30 input sources with its 15 channels. For cases where more sources are required, Arrakis has designed the ARC-16SW switcher with PC computer control. In this way, mainframe module positions are not used for remote selector switching,

The ARC-16SW is ideal for adding more inputs to your MARC-15 console such as network feeds, remotes, etc. This option gives the MARC-15 console the capacity to handle big studio jobs. For ease of use, the ARC-16SW switcher is even controlled by the same PC as is connected to your MARC-15 console.

Windows PC control software



The software supplied with the ARC-16SW is designed for use on Windows PCs using Windows-XP or VISTA. All of the inputs and outputs can be software labeled for ease of use. Outputs can also be assigned as inputs and the software will automatically remove any feedback paths from the setup.

ARC-16SW switcher



The ARC-16SW analog routing switcher is designed to be mounted on a wall or within a furniture pedestal similar to a common patch panel system. It features 16 stereo balanced inputs with trimpot level control and 3 stereo balanced outputs also with trimpot level control.

Software features

the optional PC USB module contains a built-in, Windows compatible, USB sound card for USB connection to a PC. (maximum of one module per PC)

'Free' Digilink-Xtreme software for 'Live On Air' with the MARC-15
Arrakis Digilink-Xtreme software will recognize the PC-USB module in the **MARC-15** console and operate in the 'free' mode to provide 'Live On Air' features that are ideal for broadcast, internet, or podcast style radio applications.

- control the PC audio Play List from the Console !!!
- 500 event Play List for manually assembling a show
- Start & stop the Play List by turning a USB console module on and off
- Cue audio files through the console while playing On Air (uses PC sound card for 2nd play)
- Jingle box supports playing 3 of up to 300 carts at the touch of a button
- Set the fade parameters on Songs for perfect crossfades in the Play List
- Record the console Audition or Utility bus mix direct to the PC
- Phoner recorder / editor for recording callers
- supports up to 300 audio files in the Library
- much much, more...

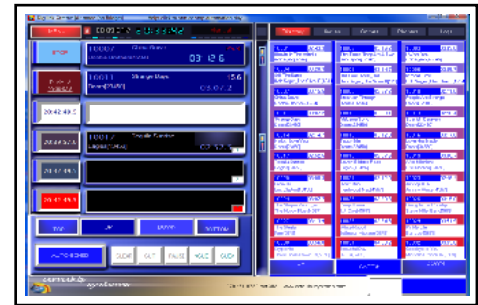

Digilink-Xtreme for 'Live Air' & 'Automation'

Digilink-Xtreme Software for Hard Disk Automation (\$100/month)

For the ultimate in Automation, Digilink-Xtreme software (optional) provides complete hard disk based automation features for the PC USB module in the MARC-15 console. Unlike standard Xtreme for satellite automation which includes the 'Bridge' routing switcher, Xtreme for the MARC-15 uses the console for audio playback & recording. Where satellite based automation selects between multiple satellite audio feeds, Xtreme for the MARC-15 plays entirely from audio files stored on the hard disk and does not control external sources at all. This makes Xtreme for the MARC-15 ideal for hard file based automation for broadcast or internet radio applications.

The power of this system lies in the merging of console and PC into a single integrated play and record studio. The ability to use the console to mix and control recording to the PC makes this system perfect for producing recorded programs. Use the MARC-15 console to produce your live air segments and then go fully automated for the rest of the day or week.

- the Xtreme Solutions Program provides software, phone training, phone & email support, and software upgrades
- No contract required, cancel at any time if the Solutions Program doesn't meet your needs
- less than the monthly cost of most cell phone, cable TV, & wideband internet services
- supports > 4000 audio files in the Library
- Automate up to a Week in advance with up to 100 events per hour
- Voice track your automated hours quickly and easily with Xtreme
- Music Scheduling, powerful and flexible is standard in Xtreme
- 'X-sched' traffic software for a separate traffic office is standard with Xtreme
- Arrakis 'X-Edit-Pro' production software is 'Free' with the Solutions Program
- 'Xtreme-studios' software for PC only News rooms and Remotes is standard with Xtreme
- be live on air with the Console and then Automate the rest of your day or week
- **Download Xtreme from the Arrakis website and try it out (www.arrakis-systems.com)**

Technical features

The MARC-15 console by Arrakis Systems inc. is the culmination of > 25 years of leadership in the design of analog and digital Radio consoles and > 15 years as the leader in hard disk automation for Radio.

Mechanical

Switch type:	momentary, 5 million operation, for all front panel switches
Switch illumination:	LED, no incandescent lamps to burn out
Linear Fader type:	conductive plastic for highest possible resolution and life
Rotary Fader type:	conductive plastic for highest possible resolution and life, 15,000 cycles
Rotary fader attachment:	ribbon cable to a plug on the module
IC sockets:	all socketed for ease of service
VU meters:	true VU ballistics

Electronic

Audio switching:	electronic switching with CMOS ICs for ultra high performance and reliability (no switches to clean)
Audio level adjust:	for the ultimate in audio performance, audio is passed through the linear and rotary faders
Operational amplifiers:	NE5532
Mic preamp:	SSM2019, high performance IC with 1.5dB noise figure and .01% THD at gain = 100
Phantom power:	48VDC, with external power supply
Logic ICs:	advanced CMOS logic for high noise immunity

Logic

Muting:	reed relay isolated (50 milliamps max)
Mic Turret logic:	on-off-cough-talkback-tally, buttons require dry closure to ground, tally is to ground
Channel Source control:	on and off, reed relay isolated (50 milliamps max)

Electronic Specifications

Stereo Line Input

Freq Response-	+(-).5dB 20-20kHz
S/N-	-82dB typ, +8dBu in, +8 dBu out
THD-	.01% typ, +8dBu in, +8 dBu out
CMRR-	-75dB typ 1kHz
Max Input-	+23dBu, balanced

Mono Mic Input

Freq Response-	+(-).5dB 20-20kHz
EIN-	-115dBu typ, -50dBu in, +8 dBu out
THD-	.05% typ, -50dBu in, +8 dBu out
CMRR-	-60dB typ 1kHz

Impedances

Mic Input-	> 2000 ohms
Line Input-	> 10000 ohms
Outputs-	< 100 ohms

System

Max Output-	+23dBu balanced
Stereo Separation-	-75dB typ 1KHz
Pgm to Aud XTalk-	-80dB typ 1KHz
	-70dB typ 20kHz
Cue to Pgm XTalk-	-90dB typ 1KHz
	-75dB typ 20kHz

On Air Light Logic: reed relay, 50mA max

POWER SUPPLY

110vac - 220 VAC, 50-60 hz, autosensing
Certified: UL, CE, CS, CB
External inline module: 3"W x 5 3/4"L x 1 3/4"D

PHYSICAL SPECIFICATIONS

Dimensions - Depth - 20",
Height - 6 3/4"
Width - 37 1/2"

Installation

- Fast & easy installation
- All IO is by World standard RJ45 connectors
- Cables with RJ45s on one end are supplied standard with the MARC-15
- Optional cables are available with XLR and RCA on one end for convenience

The MARC-15 is quick and easy to install. The meter panel hinges up and back to provide fast access to the RJ45 IO connectors and trimpots. The cabling exits through the bottom rear of the console and can be either through the table or simply out the rear of the console above the tabletop.

Ten foot cables (connectorized at one end with molded RJ45 connectors) are provided for the output module and the 'A' inputs for the input modules. This is an expensive option for most consoles but is standard with the MARC-15.

The power supply is an external 'brick' type module that supports 110VAC - 220VAC for domestic or international installations. It simply plugs into the rear of the console.



Cables exit the rear bottom of the console.

Standard cables (supplied)



Ten foot cables (molded RJ45 on one end other end open) are supplied standard with the MARC-15

optional cables



Arrakis can supply the audio and logic cables wired on both ends for your studio.

The meter panel hinges for access to console I/O and trimpots



Electronic Block Diagram

RJ45 (8 wire)

Mic module

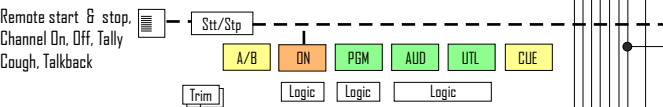
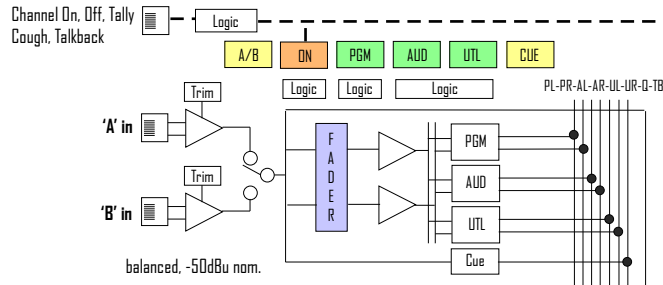

Stereo Line module

PC USB module

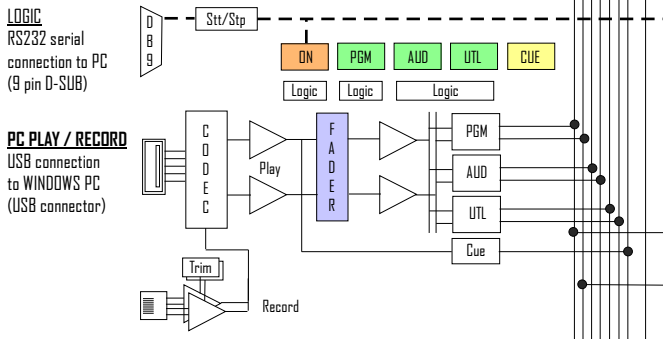

Phone module 1

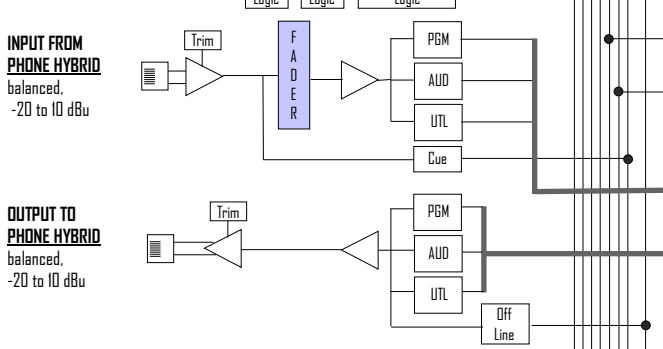

Phone module 2

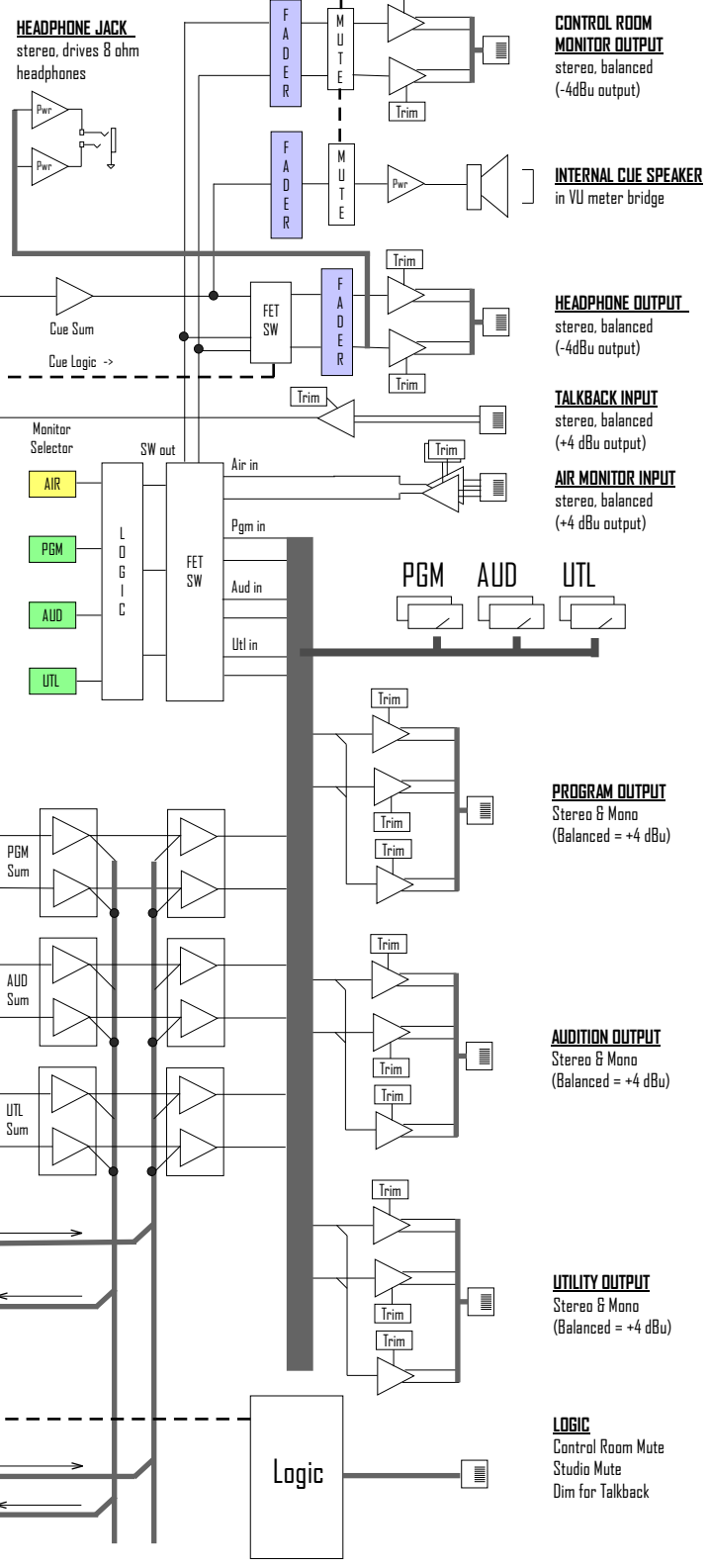

CONTROL ROOM MONITOR OUTPUT
stereo, balanced
(-4dBu output)

INTERNAL CUE SPEAKER
in VU meter bridge

HEADPHONE OUTPUT
stereo, balanced
(-4dBu output)

TALKBACK INPUT
stereo, balanced
(+4 dBu output)

AIR MONITOR INPUT
stereo, balanced
(+4 dBu output)

PROGRAM OUTPUT
Stereo & Mono
(Balanced = +4 dBu)

ADDITION OUTPUT
Stereo & Mono
(Balanced = +4 dBu)

UTILITY OUTPUT
Stereo & Mono
(Balanced = +4 dBu)

LOGIC
Control Room Mute
Studio Mute
Dim for Talkback

MARC-15 console

beautiful, functional, and durable...



ARRAKIS
advancedradio

6604 Powell St.
Loveland Colorado 80538
Voice 970-461-0730
www.arrakis-systems.com

Warranty: 1 year limited

Specifications subject to change without notice